

Sturm!  
нас рекомендуют друзья

### CD3318LP

NO.	DESCRIPTION	NO.	DESCRIPTION
1	CHUCK SCREW	27	UPPER GEAR RING
A2	CHUCK	28	THE FIRST PLANET CARRIER
3	BIG CIRCLIP	29	THE FIRST PLANET GEAR
4	TORQUE ADJUSTMENT PIECE	30	WASHER
5	TORQUE ADJUSTMENT RING	31	SCREW
6	TORQUE ADJUSTMENT NUT	32	MOTOR COVER
7	SPRING	33	MOTOR GEAR
8	BIG WASHER	34	MOTOR
9	PIN	35	TWO SPEED CHANGE BUTTON
10	STEEL BALL	36	SPRING
A11	SPINDLE	37	RIVET
12	BEARING 689Z	39	DIRECTION CHANGLE LEVEL
13	TORQUE ADJUSTMENT SPRING	40	SWITCH
14	GEAR BOX	41	BATTERY CONNECTION FOOT
15	TWO SPEED CHANGE SPRING	42	HOUSING BUCKLE
16	GEAR BOX PIN	44	SCREW
17	CIRCLIP	45	BATTERY PACK
19	INNER GEAR RING	46	CHARGER
20	THE THIRD PLANET CARRIER	47	SPINDLE LOCK RING
21	THE THIRD PLANET GEAR	48	SPINDLE LOCK PIN
22	WASHER	49	SPINDLE LOCK BLOCK
23	THE SECOND PLANET CARRIER	A100	GEAR BOX ASSEMBLY
24	THE SECOND PLANET GEAR	101	MOTOR ASSEMBLY
25	MOVING GEAR RING	888	HOUSING ASSEMBLY
26	GEAR BOX BUSH		

ST-RU20170602 VER:2.1

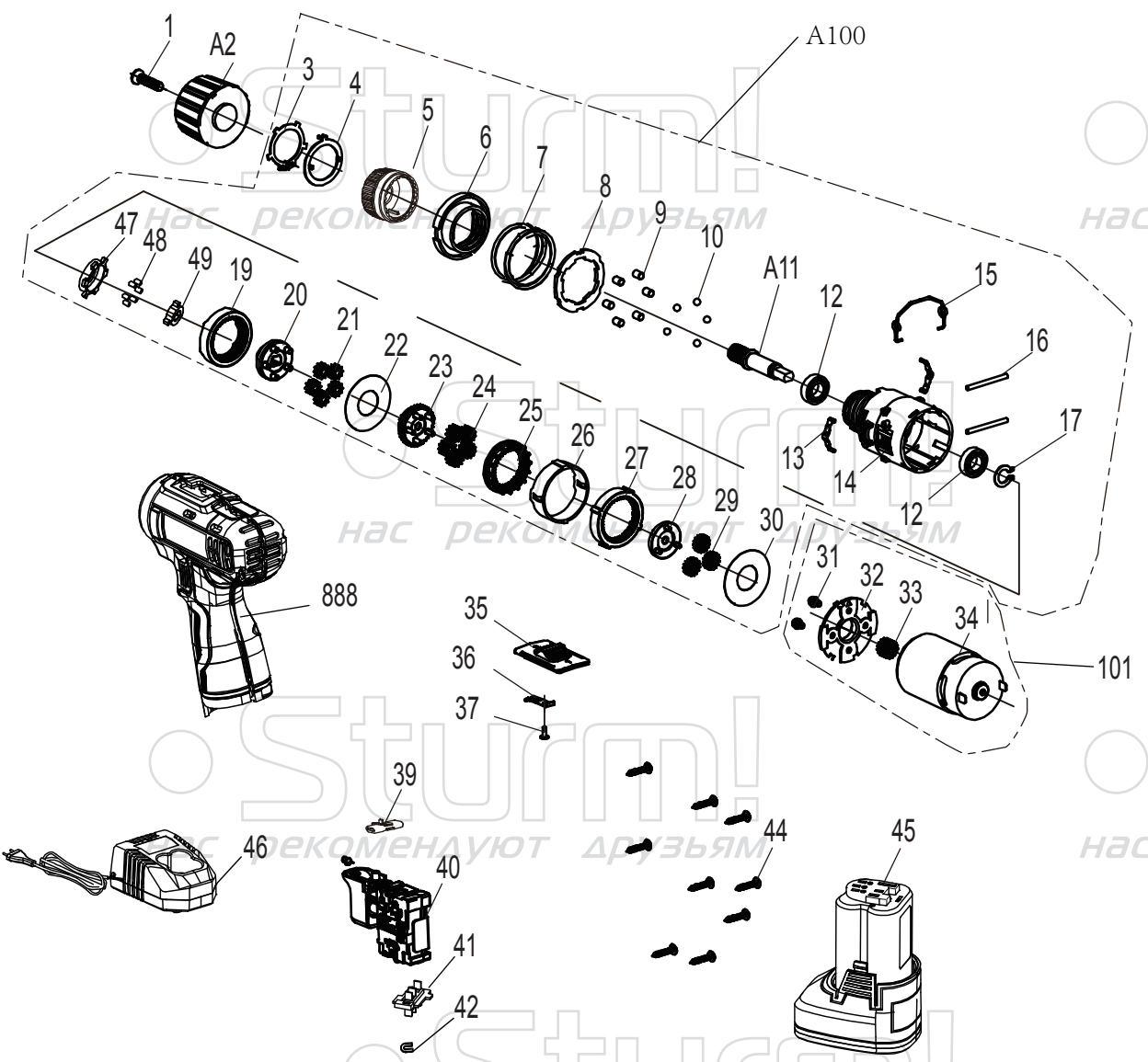

Sturm!  
нас рекомендуют друзья

Sturm!  
нас рекомендуют друзья